Contents

OVERVIEW	2
Features	2
Control-it™ 5001 case markings and led lights.....	3
Control-it™ 5007 case markings and led lights.....	4
Functional Block Diagram.....	5
LED indicator functions	5
Quick Test.....	6
Installation	7
Installation when used with Multiple Devices	8
Systems with more than 6 converters	8
Specifications	10
Declaration of Conformity 2001	11

OVERVIEW

The **Control-it**[™] **5001** and **5007** are fully automatic RS232 to RS485 converters, making it easy for you to communicate with external devices on RS485.

They have auto baud-rate detection, optical isolation, and automatic transmission control all in the same unit.

The **Control-it**[™] **5007** is a DIN rail mountable version of the **5001**.

Just plug the **Control-it**[™] **5001** or **5007** into the serial port and off you go!

Features

- Auto baud-rate detection. It adjusts itself to the data transmitted and causes a turnaround within 200µsec at a baud rate of 9600bps.
- Fully isolated to prevent any damage to your computer caused by high voltage or by a short circuit of the external device(s).
- No transmission control (RTS and DTR) signals are necessary.
- 1.8km transmission range at 115.2k baud or 3.6km at 56k baud and less.
- Due to high quality, low current components no separate power supply is needed for the RS232 side.
- Lid mounted indicator LEDS allow you to see clearly that the converter is correctly connected to external devices and that data is being received and transmitted.
- RS232 side is supplied with a lead and 9way female connector.
- Very fast turnaround time for data that is 8 bit no parity.
- Connection of up to 32 modules to one converter.

Control-it™ 5001 case markings and led lights

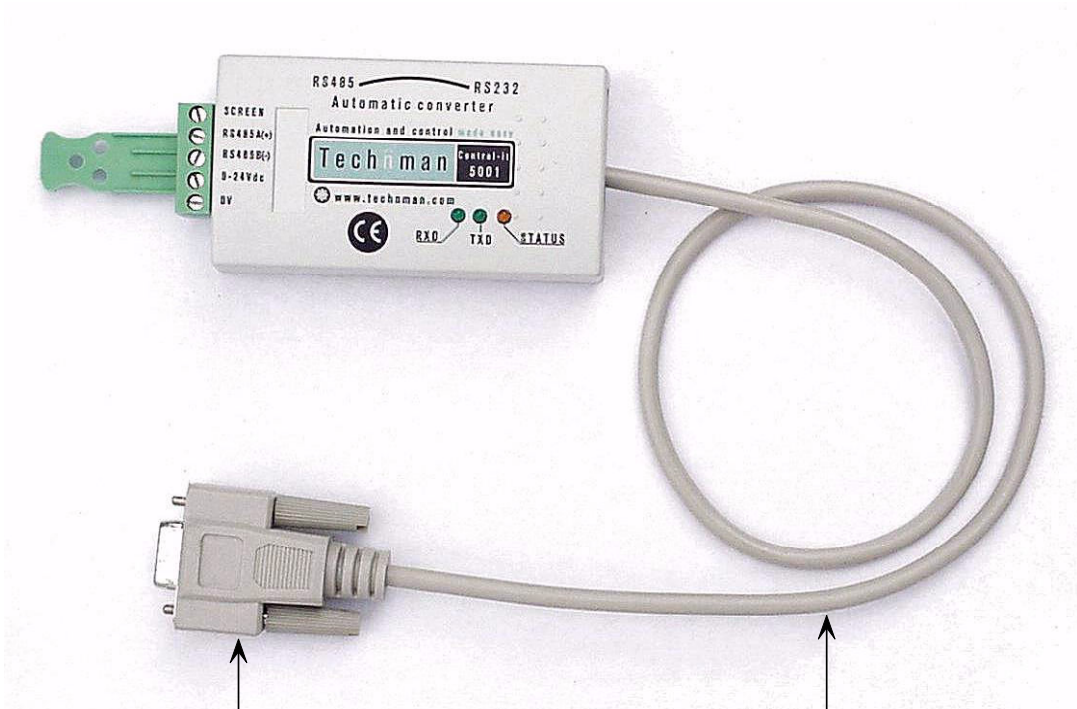

RS232 plug - DB9
Female connector

RS232 cable - 500mm
long shielded cable

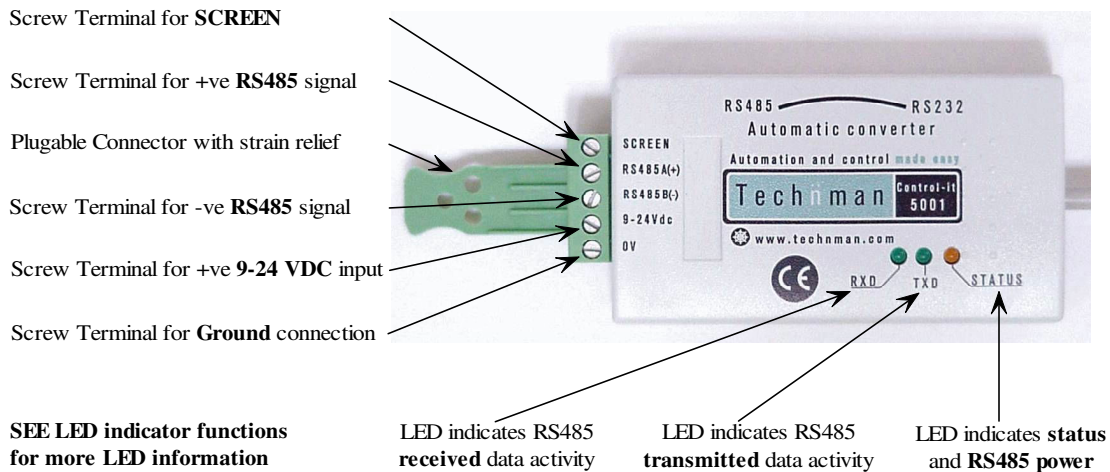

The **Control-it™ 5001** comes in a robust, flame-retardant ABS case. It is provided with 500mm shielded cable and a DB9 female connector.

Control-it™ 5007 case markings and led lights

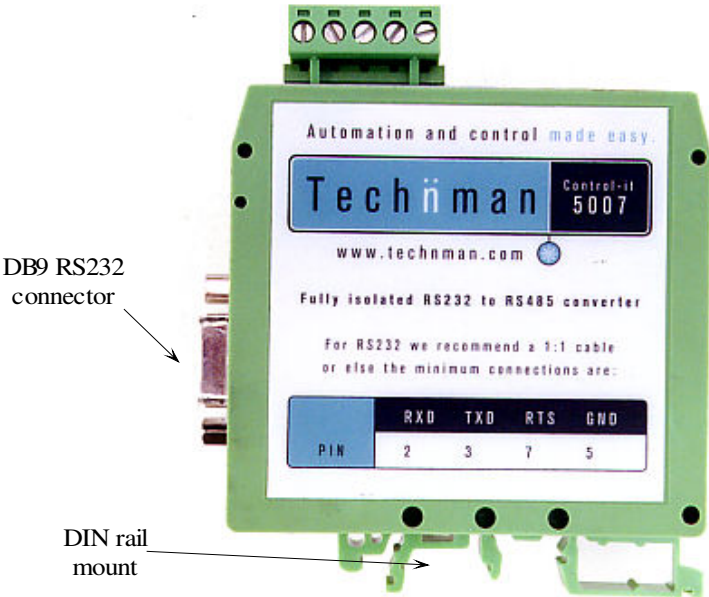
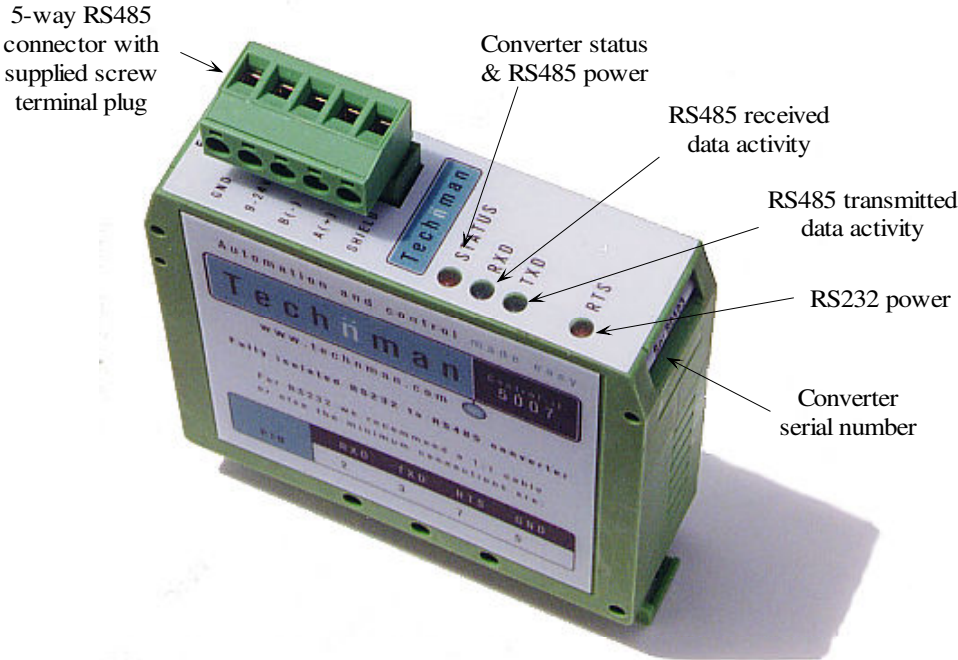

The **Control-it™ 5007** comes in a DIN rail mountable, flame-retardant case for use within standard electrical cabinets.

Functional Block Diagram

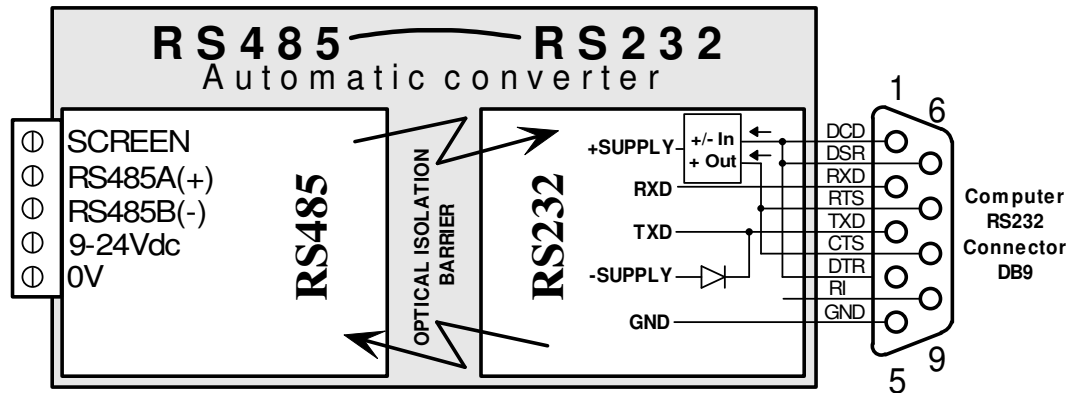

NB The positive supply for the RS232 side of the converter is generated from the RTS or DTR lines that can be either +ve or -ve, therefore at least one line must be connected.

LED indicator functions

- | | |
|------------------------|--|
| RXD | Indicates data flow <u>to</u> the PC |
| TXD | Indicates data flow <u>from</u> the PC |
| RTS (5007 only) | Indicates sufficient power to the RS232 side (from the PC). |
| STATUS | Has three functions: |
| | <ul style="list-style-type: none">• A <u>Steady light</u> when initially connected indicates power is applied to the RS485 port. After sending approximately 5 characters (such as a carriage return) it will adjust to one of the two modes:• A <u>Single pulse</u> every two seconds indicates <i>the unit is in UART mode</i>, where each character is checked individually for quick turnaround at the end of transmission. Maximum turnaround delay is 2 bits. The converter will use this mode if 8 bit no parity or 7 bit with parity is used. For example at 9600bps the turnaround delay time is (2/9600) 0.2ms. |

-
- A Double pulse every two seconds indicates *the unit is in timed mode*, where the turnaround time is one character length or 11 bits. The converter will go into this mode if non-standard data is used. For example at 9600bps the turnaround delay time is $(11/9600)$ 1.1ms

Quick Test

This test is designed to give you a quick indication that the computer is communicating with the converter.

1. Plug converter into serial port COM1 & apply power (9-24Vdc) to the RS485 side.
2. Go into DOS mode and type the following: **copy con: com1:**
3. Press the **ENTER** key
4. Press the U key 10 times, followed by **CTRL Z**.
5. Watch the TXD light as you press the **ENTER** key. The typed characters will be sent to COM1 and the TXD light on the Converter lights up momentarily.

Installation

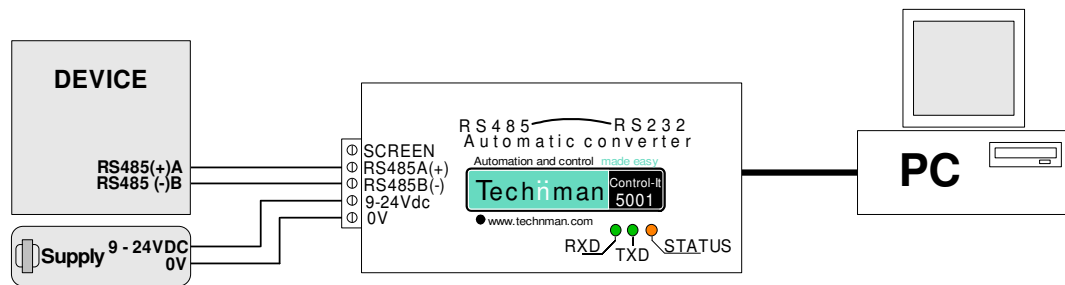

1. Connect the DB9 connector to a **COM** port on your PC. With the **Control-it™ 5007**, the RTS LED will be lit.
2. Wire the RS485 connector to your device.
 - We recommend a **shielded, twisted pair** data cable. **Do not** remove more than 100mm of shield from each end of the cable when connecting to devices. Connect shield to ground at **one point only**.
 - For short wire communication, such as bench-top or laboratory set-ups, no screened data cable is necessary between the converter and your device, unless it is in an electrically noisy environment.
3. Connect the power supply (9 - 24Vdc) to the converter. The **POWER** light will come on at this point.



Make sure 24V does not get connected to the RS485 terminals.

Installation when used with Multiple Devices

The **Control-it™ 5001** or **5007** can be connected with up to 32 devices on the one network.

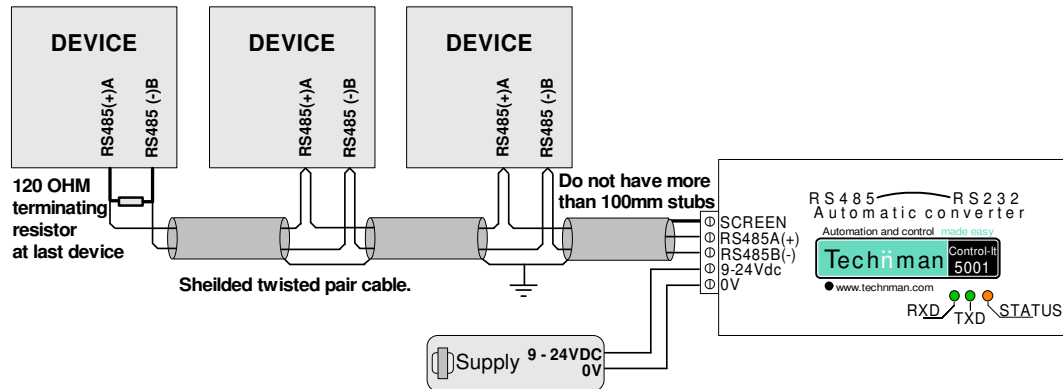

- Always connected devices in 'daisy-chain', as shown, with each device connected in a row. Never connect devices in a 'star', as each branch will create unwanted reflections, leading to data errors.
- A cable branch to a device that is less than 5 meters long is acceptable.

Systems with more than 6 converters

Bias resistors within the converter ensure that the signal lines are held in the correct state when no transmitter drive is present. However, multiple units and long cable runs can hinder the transmitter's ability to pull against them, in which case they can be negated by removing the bias jumpers.

- For the 5001, unscrew the lid and remove jumpers from all units apart from the two on each end.
- For the 5007, move the Bias switches on the rear of the unit to OFF for all units apart from the two on each end.

The following graph may be used to approximate the number of units that can be connected to a line, considering cable distance, before the bias jumpers must be removed.

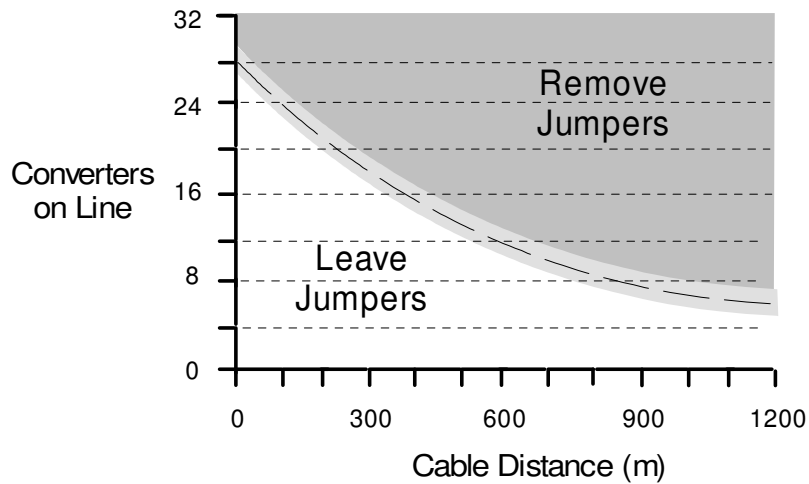

As examples, 18 converters may be used if the cable length doesn't exceed 300m, but only 6 converters can operate over 1.2km.

The actual figure will depend on many factors such as;

- Dc resistance of cable (larger gauge increases maximum)
- Placement of units (even distribution, rather than toward far end increases maximum)

Specifications

Case Dimensions	5001	90 x 50 x 25 mm (3½ x 2 x 1")
	5007	80 x 25 x 75 mm (3¼ x 1 x 3")
Weight	5001	120g (4.2ozs)
	5007	85g (3ozs)
Storage temperature		-20° to 70° C (-4° to 158° F)
Operating temperature		0° to 50°C (32° to 122° F)
Humidity		15 to 90% relative non condensing
Transmission Distance	1.8km (6000 feet) at 115.2k baud	
	3.6km (12000 feet) at 56k baud	
Isolation Voltage		1500V max transient ¹
Power		9-24Vdc regulated or unregulated 35mA at 12Vdc on RS485 side
Connectors		DB9 female for RS232 Plug-able screw terminal connector with strain relief for RS485. 0.2 - 2.5mm ² (AWG 24 -12)
Operating mode		2 wire half-duplex point-to-point or multi-drop
Data rates		300 to 115200 bps
Indicator lights	5001	TXD, RXD, and STATUS
	5007	TXD, RXD, STATUS & RTS

¹ EN 60950 : 1992

Declaration of Conformity 2001

Manufacturer's Name: Technman Electronics Ltd
Manufacturer's Address: PO Box 302107
North Harbour Post Shop, Auckland 1330, New Zealand

declares that the product

Product name: Control-it 5000 Series Distributed Input/ Output System
Model numbers: 5001, 5005, 5006, 5007, 5020, 5030, 5040, 5050, 5100, 5101, 5251, 5258
Product options: All

conforms to the following product specifications:

Safety Regulations: Low Voltage Directive 73/23/EEC 22 July 1993 and the UK Electrical Equipment Safety Regulations 1994.
EN 60950:1992+A1+A2+A3- Primary Circuit/ Double insulation
Model 5020- Primary circuit/ Reinforced insulation
Except when these modules are incorporated into a larger mechanical device, in which case a responsible person must ensure that all appropriate safety regulations are met.

EMC Regulations: EMC Directive 89/336/EEC 3 May 1989 and 92/31/EEC 28 April 1992, article 10.1.
EN 55022:1998 Class A Device
EN 55024:1998 I.T. Equipment
EN 50082-2:1995 Generic Industrial Device

The product herewith complies with the requirements of the following Directives and carries the CE marking accordingly:

Low Voltage Directive 73/23/EEC
EMC Directive 89/336/EEC

The product was tested in a typical configuration with a personal computer system.

For compliance information contact:

Director
Technman Electronics Ltd.
PO Box 302107
North Harbour Post Shop
Auckland 1330
New Zealand.

or

Quality Assurance Director
Amplicon Liveline Ltd
Centery Industrial Estate
Hollingdean Road
Brighton
UK BN2 4AW

WARNING

This is a class A product. In a domestic environment this product may cause radio interference in which case the user may be required to take adequate measures.

