Contents

Overview	2
Features:.....	2
General Description	3
Control-it™5002 case markings and led lights.....	3
LED indicator functions	3
Installation when used with a single device	4
Installation when used with multiple devices	4
Quicktest	5
Control-it™ 5002 Block diagram	5
Specifications	6

Overview

The **Control-it™ 5002** converts RS232- RS485 signal to allow long-distance communication between your PC and any external devices. These external devices may be up to 1.2 kilometres away. The **Control-it™ 5002** can be connected to up to 32 external devices.

The **Control-it™ 5002** has been developed specifically for educational and development laboratory use. It contains no optical isolation and therefore is not recommended for noisy commercial or industrial environments.

The **Control-it™ 5002** has indicator LEDS to assist with trouble-shooting. You can see clearly that the converter is correctly connected to external devices and that data is being received and transmitted.

Features:

1. Easy to connect
2. No jumper settings
3. Small size and light weight unit
4. Screw terminal connector on RS485 side
5. Low cost RS232 converter
6. Works between 0 and 115000 bps

Communication distance up to 1.2km

General Description

Control-it™5002 case markings and led lights

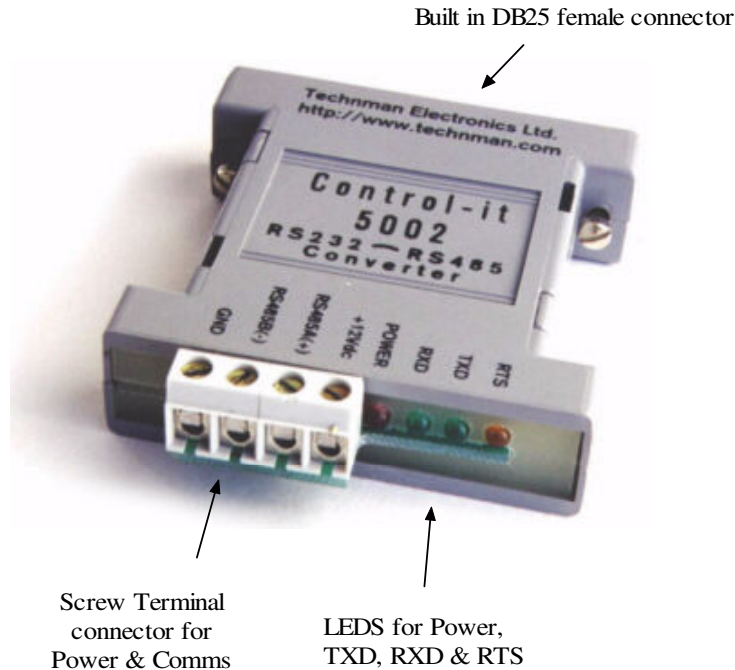

The **Control-it™ 5002** comes in a robust case with a built-in DB25 female connector.

LED indicator functions

RXD LED is the *data receive* indicator relative to the PC.

TXD LED is the *data transmit* indicator relative to the PC.

RTS LED means that the **Control-it™ 5002** is transmitting onto the RS485 line.

POWER LED indicates if 12 VDC power is applied.

Installation when used with a single device

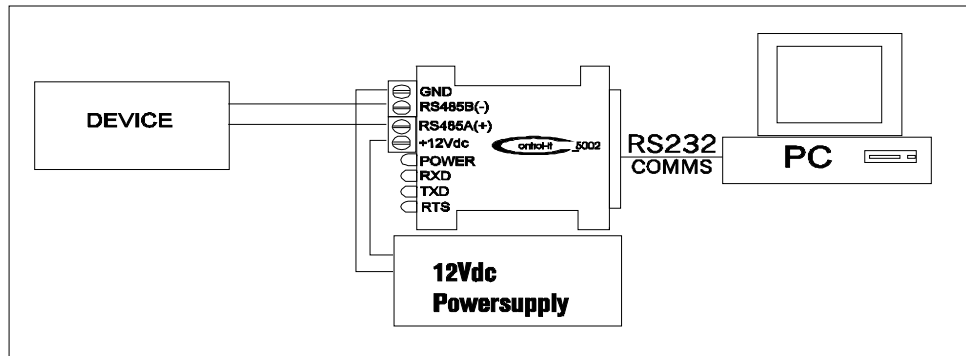

This configuration is commonly used for bench or laboratory applications.

For short wire communication no screened data cable is necessary between the **Control-it™ 5002** converter and device, unless it is an electrically noisy environment.

Plug unit into the 25-way serial port connector and apply 12VDC to the **Control-it™ 5002** converter. The **POWER** light must come on at this point, if it doesn't then check the polarity.

Installation when used with multiple devices

Connect a 120 Ω terminating resistor between **RS485A(+)** and **RS485B(-)**, a 3.9k Ω resistor between +12V and RS485A(+) and a 820 Ω resistor between **GND** and **RS485B(-)** at the last device (end of comms cable). These resistors are necessary to bias the RS485 line to a known idle state.

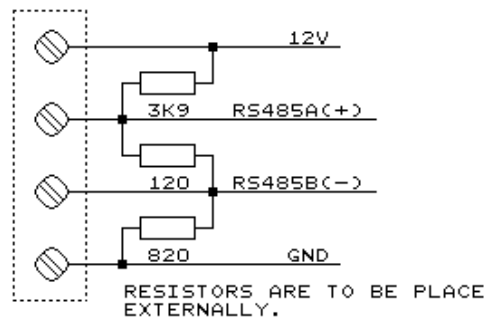

We recommend a **shielded 2 core twisted data cable** for all industrial installation or when used near any mains wiring or ducting or electrically noisy environment.

Do not remove more than 100mm shield from the shielded data cable when connecting to devices.

Connect **shield** to ground at only one point.



Make sure 24V does not get connected to the RS485 terminals.

Quicktest

- Plug unit into serial port of PC, connect 12VDC power.
- Using Windows95/98, go into DOS mode and type the following:
copy con: com1: then press "ENTER"
- press a few keys and than "CTRL Z" and the TXD light should light up until all characters are sent.

Or you can use any terminal program to test the unit.

- Typing keys on the PC keyboard will cause the RTS and TXD lights to blink on. This happens even with a single 5002 plugged into the PC and not connected to any device on the RS485 line.

Control-it™ 5002 Block diagram

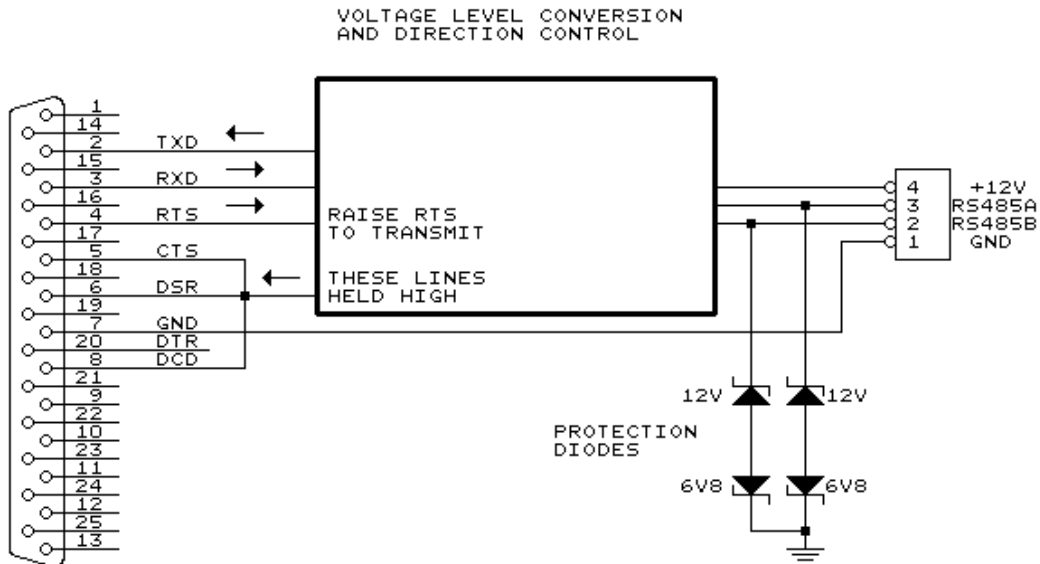

Specifications

Enclosure	DB25 Breakout Box
Transmission Distance	1.2km (4000 feet)
Weight	38g
Dimensions	66(L) x 56(W) x 19(H)
Operating temperature	32° to 140° F (0° to 60°C)
Storage temperature	-4° to 158° F (-20° to 70° C)
Humidity	15 to 90% relative non condensing
Power	12Vdc regulated or unregulated 35 mA at 12Vdc
Connectors	DB25 female for RS232 Screw terminal connector for RS485.
Operating mode	2 wire half duplex point to point or Multidrop
Data rates	0 > 115.2 kbps
Indicator lights	TXD, RXD, RTS and POWER