Contents

Overview	2
Features	2
General Description	3
Control-it™ 5256 case markings and led lights.....	3
Control-it™ 5256 Block diagram.....	3
LED indicator functions	4
Quick Test.....	4
Installation	5
Installation when used with multiple devices	6
Specifications	8
Declaration of Conformity 2002.....	9

Overview

The **Control-it™ 5006** is an automatic RS232 to RS422 converter that allows your PC to communicate with remote devices 1.8km away at 115.2k baud or 3.6km at 56k baud via a RS232 serial port.

Features

- No need to use DTR or RTS to control the transmission. Automatically goes into transmit when the PC sends a character and immediately returns to idle once the character or characters have been sent.
- Automatic baud rate determination.
- Very fast turnaround time for data that is 8 bit no parity.
- Fully isolated. Therefore safe to use on any Laptop or PC.
- Three LED indicators - STATUS (power and mode), RXD (receive data) and TXD (transmit data) – provide valuable operational information.
- RS422 transmitter can handle up to 32 modules.

General Description

Control-it™ 5256 case markings and led lights

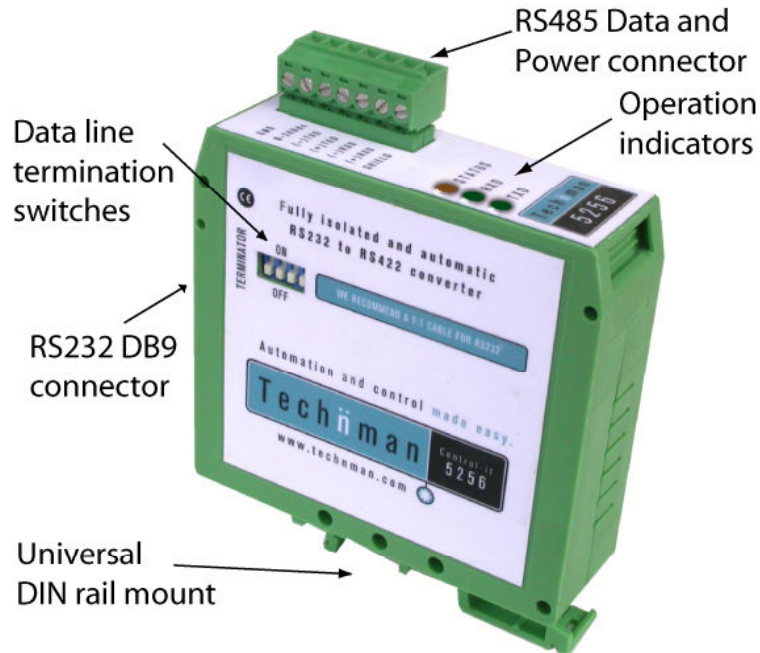

Figure 1

The **Control-it™ 5256** comes in a DIN rail mountable, flame-retardant case for use within standard electrical cabinets.

Control-it™ 5256 Block diagram

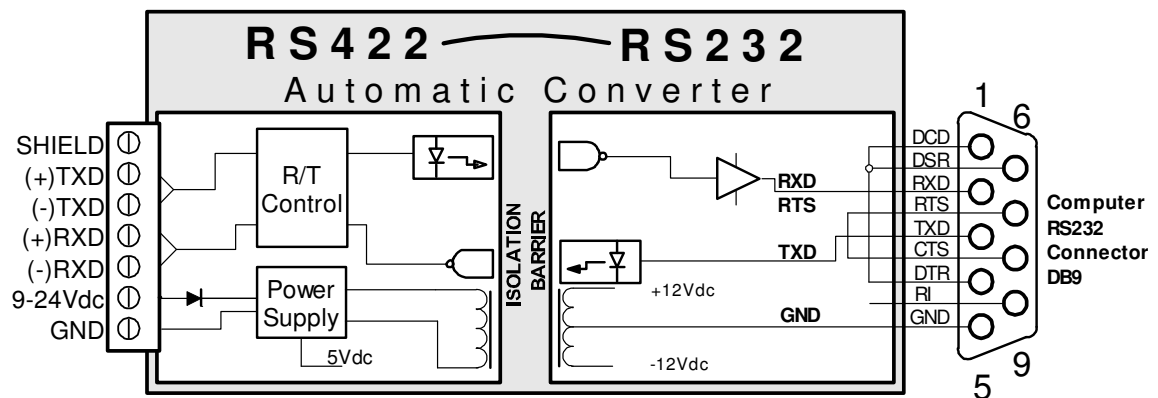

Figure 2

LED indicator functions

RXD LED shows data flow to the RS232 device (e.g. your PC).

TXD LED shows data flow from the RS232 device.

STATUS LED has three functions.

1. Initially it will light up continuously when power is applied to the RS422 port. After sending *5 characters* (such as a carriage return) it will adjust to one of the two modes:
2. One pulse every two seconds indicates *the unit is in UART mode*, where each character is checked individually for quick turnaround at the end of transmission. The converter will use this mode if 8 bit no parity or 7 bit with parity is used.
 - Maximum turnaround delay is 2 bits. For example at 9600bps the turnaround delay time is $(2/9600)$ 0.2ms.
3. Two off pulses after each other every two seconds indicates *the unit is in timed mode*, where the turnaround time is one character length or 11 bits. The converter will go into this mode if non-standard data is used.
 - For example at 9600bps the turnaround delay time is $(11/9600)$ 1.1ms.

Quick Test

This test is designed to give you a quick indication that the computer is communicating with the converter.

1. Plug converter into serial port COM1 & apply power (9-24Vdc) to the RS422 side.
2. Go into DOS mode and type the following: **copy con: com1:**
3. Press the **ENTER** key
4. Type a few characters followed by **CTRL Z**.
5. Watch the TXD light as you press the **ENTER** key. The typed characters will be sent to COM1 and the TXD light on the Converter lights up momentarily.

Installation

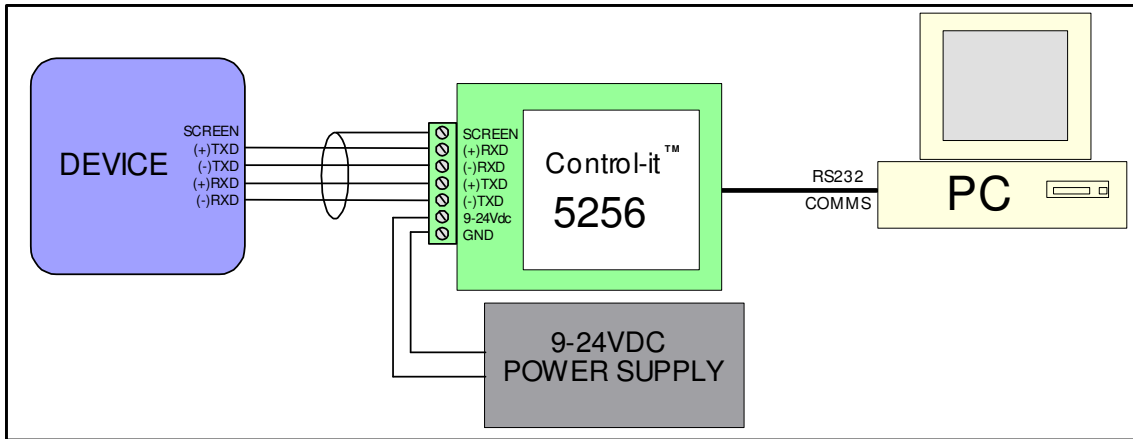

Figure 3

1. Connect the DB9 connector to a **COM** port on your PC.
2. Move the termination switches to ON.
3. Wire the RS422 connector to your device as per figure 3. Refer to table 1 for data line connection details.

Data Line Connections	
Converter	Device
TXD A(+)	RXD A(+)
TXD B(-)	RXD B(-)
RXD A(+)	TXD A(+)
RXD B(-)	TXD B(-)

Table 1 – Data line connections.

- We recommend a **shielded, four core, twisted pair** data cable. **Do not** remove more than 100mm of shield from each end of the cable when connecting to devices. Connect shield to ground at **one point only**.
- For short wire communication, such as bench-top or laboratory set-ups, no screened data cable is necessary between the **Control-it™ 5256** converter and your device, unless it is in an electrically noisy environment.

- If the cable is longer than 100m, move the termination switches to ON position on the **last unit only**.
4. Connect the power supply (9 - 24Vdc) to the **Control-it™ 5256** converter. The **STATUS** light will come on at this point.



Make sure 24V does not get connected to the RS422 terminals.

Installation when used with multiple devices

The **Control-it™ 5256** can be connected with up to 32 devices on the one network.

Installation is essentially the same as described on page 5, with a few additional considerations.

1. Always connected devices in 'daisy-chain', as shown in figure 4, with each device connected in a row. Never connect devices in a 'star', as each branch will create unwanted reflections, leading to data errors.

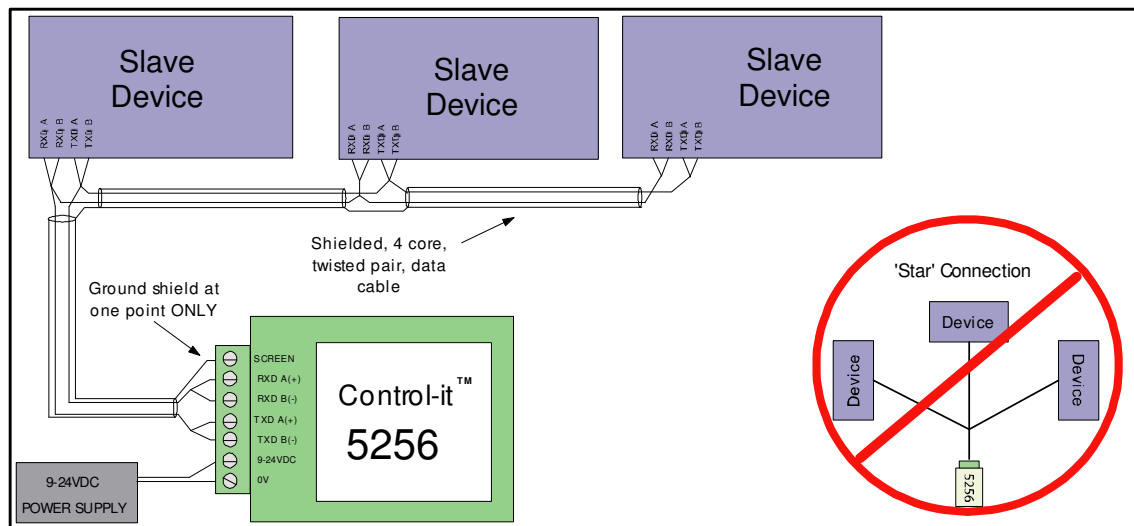





Figure 4 – Connection of a multi-drop network in 'Daisy-chain' configuration considerations.

2. Connect slave data lines like-to-like, i.e. (+)TXD to (+)TXD etc., then to converter as per table 1 (page 5).

-
3. If more than one **Control-it™ 5256** is used, the termination switches must be set correctly.
 - Move the switches on the converters at the extreme ends of the line to ON.
 - Move the switches on all other converters to OFF.

Specifications

Case Dimensions	80 x 25 x 75 mm (3¼ x 1 x 3")	
Weight	85g (3ozs)	
DIN mount		32 x 15mm, EN50035
		35 x 7.5mm, EN50022
		15 x 5mm, EN50045
Storage temperature	-20° to 70° C (-4° to 158° F)	
Operating temperature	0° to 50°C (32° to 122° F)	
Humidity	15 to 90% relative non condensing	
Transmission Distance	1.8km (6000 feet) at 115.2k baud	
	3.6km (12000 feet) at 56k baud	
Isolation Voltage	1500V max transient ¹	
Power	9-24Vdc regulated or unregulated 56mA at 12Vdc on RS485 side	
Connectors	RS232	DB9 female for RS232
	RS485	Plug-able screw terminal connector. 0.2 - 2.5mm ² (AWG 24 -12)
Operating mode	4 wire full duplex point-to-point or Multi-drop	
Data rates	300 to 115200 bps	
Indicator lights	TXD, RXD, & STATUS	

¹ EN 60950 : 1992

Declaration of Conformity 2002

Manufacturer's Name: Technman Electronics Ltd
Manufacturer's Address: PO Box 302 107, Auckland 1330, New Zealand

declares that the product

Product name: Control-it 5000 Series Distributed Input/ Output System
Model numbers: 5001, 5005, 5006, 5007, 5020, 5030, 5040, 5050, 5100, 5101, 5255, 5256, 5258
Product options: All

conforms to the following product specifications:

Safety Regulations: Low Voltage Directive 73/23/EEC 22 July 1993 and the UK Electrical Equipment Safety Regulations 1994.
EN 60950:1992+A1+A2+A3- Primary Circuit/ Double insulation
Model 5020- Primary circuit/ Reinforced insulation
Except when these modules are incorporated into a larger mechanical device, in which case a responsible person must ensure that all appropriate safety regulations are met.

EMC Regulations: EMC Directive 89/336/EEC 3 May 1989 and 92/31/EEC 28 April 1992, article 10.1.
EN 55022:1998 Class A Device
EN 55024:1998 I.T. Equipment
EN 50082-2:1995 Generic Industrial Device

The product herewith complies with the requirements of the following Directives and carries the CE marking accordingly:

Low Voltage Directive 73/23/EEC
EMC Directive 89/336/EEC

The product was tested in a typical configuration with a personal computer system.

For compliance information contact:

Director
Technman Electronics Ltd.
PO Box 302 107
Auckland 1330
New Zealand

or

Quality Assurance Director
Amplicon Liveline Ltd
Centery Industrial Estate
Hollingdean Road
Brighton
UK BN2 4AW

WARNING

This is a class A product. In a domestic environment this product may cause radio interference in which case the user may be required to take adequate measures.

Rev B