Contents

OVERVIEW	3
Features	4
General Description	5
Control-it™5258 and 5259 case markings and led lights	5
Functional Block Diagram.....	6
LED Indicator Functions	6
Operation	7
Data Parameters	7
Setting the converter address.....	8
Setting the command header	9
STX.....	9
HeAdEr	9
F1.....	10
Initialising the converter.....	10
The Command Set	11
The General Command.....	11
Turn On.....	11
Turn Off.....	11
Acknowledge.....	12
Installation	13
Common to all Set Ups.....	13
Minimum System.....	13
Best Practices	15

Termination Switches	16
Troubleshooting	17
Specifications	18
Declaration of Conformity 2001	19

OVERVIEW

The **Control-it™ 5258** is a fully automatic and addressable, RS232 to RS485 converter, designed to allow networking of multiple devices on a single RS485 cable.

The **Control-it™ 5259** is a fully automatic and addressable, RS232 to RS422 converter, designed to allow networking of multiple devices on a single RS422 cable.

It has auto baud-rate detection, optical isolation, and automatic transmission control all in the same unit.

The converter is designed to:

- Only connect the RS232 device to the RS485 or RS422 network after it has been addressed, either specifically or by the broadcast command.
- Disconnect if a command is received that does not match its own address or is invalid.
- Acknowledge its presence if requested.
- Protect the RS232 device from all command characters intended for the converter.

Features

- DIP switch settable address for networking multiple devices.
- DIP switch settable command header.
- Converter address acknowledgement.
- Auto baud-rate detection. It adjusts itself to the data transmitted and causes a turnaround within 1 character length.
- Fully isolated to prevent any damage to your computer caused by high voltage or by a short circuit of the external device(s).
- No transmission control (RTS and DTR) signals are necessary.
- 1.8km transmission range at 115.2k baud or 3.6km at 56k baud and less.
- No separate power supply is needed for the RS232 side.
- Lid mounted indicator LEDS allow you to see clearly that the converter is correctly powered, when it is addressed and that data is being received and transmitted.
- DIN rail mounting with universal foot for symmetrical and asymmetrical rails.

General Description

Control-it™5258 and 5259 case markings and led lights

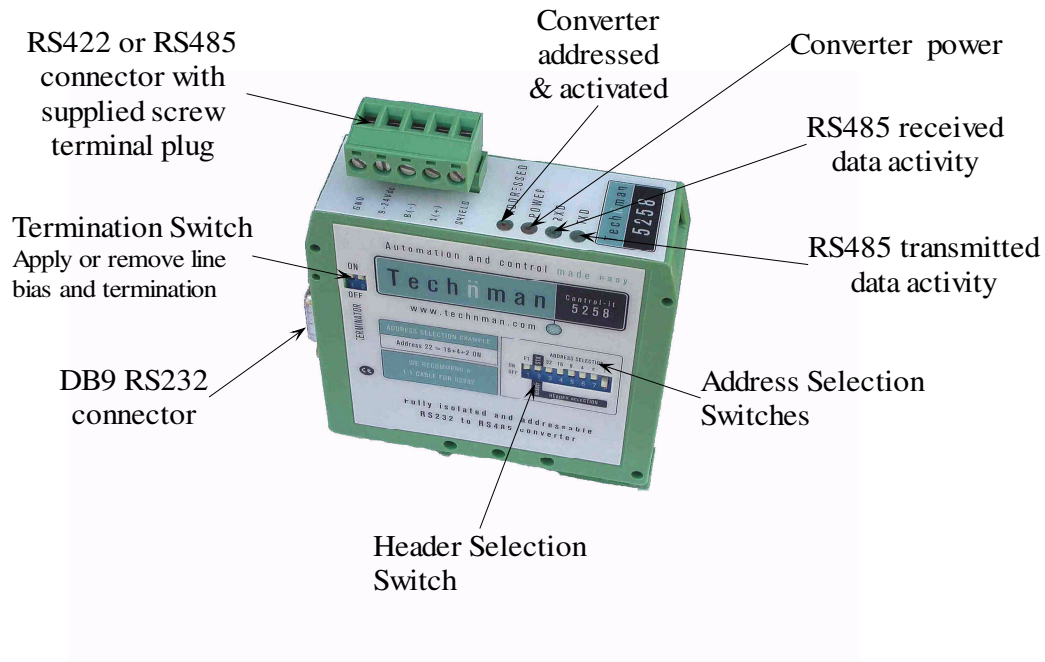

The **Control-it™ 5258** and the **5259** come in a DIN rail mountable, flame-retardant case for use within standard electrical cabinets.

Functional Block Diagram

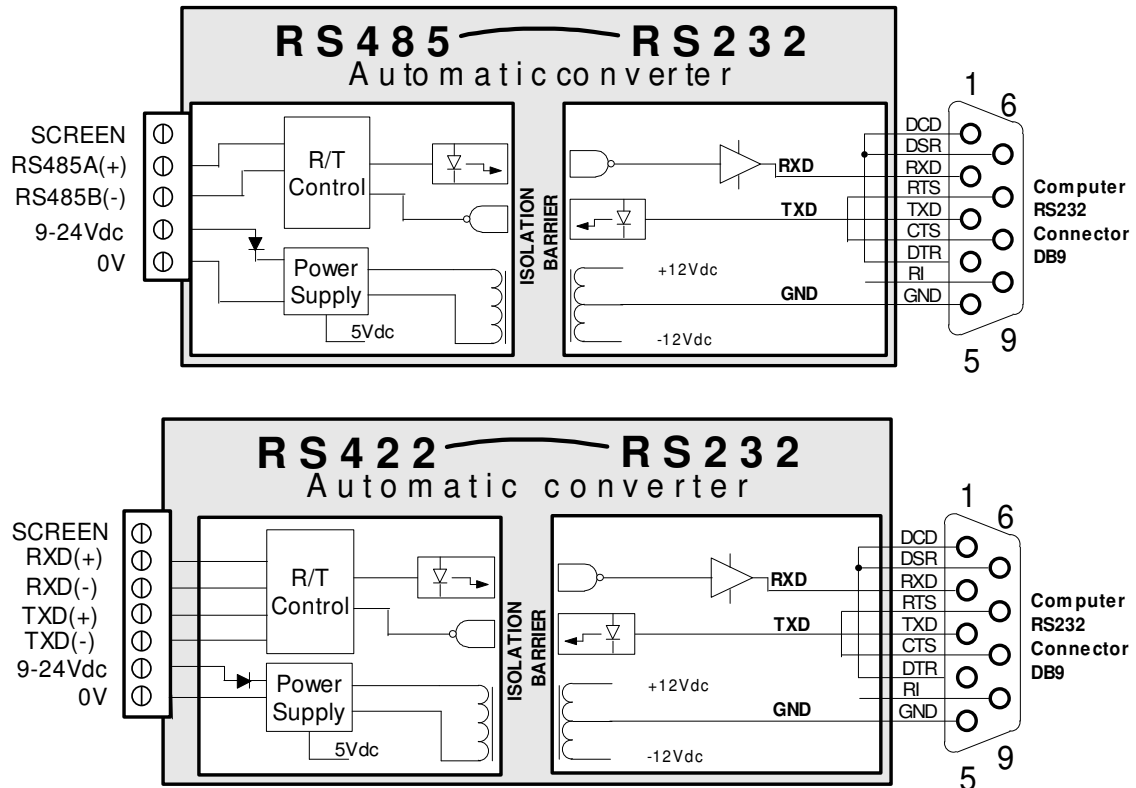

LED Indicator Functions

Four LED indicators on the converter perform the following functions;

ADDRESSED	Indicates that the converter is activated. Flashes if address 0 is selected by the address switches. Glows at half brightness after initial power up until auto bauding is completed. Refer <i>Initialising the converter</i> , page 10.
POWER	Indicates that 9 – 24Vdc is connected correctly.
RXD	Indicates data flow <u>to</u> the RS232 device.
TXD	Indicates data flow <u>from</u> the RS232 device.

Operation

The general operation of the converter takes the following form:

1. After power-up, the converter must initialise to the baud rate as described in ***Initialising the converter***, on page 10.
2. The converter is activated when it receives a command containing its address and a valid ON character, as described in the next chapters.
3. Once activated, data is free to flow through the converter in either direction, but only in one direction at a time as RS485 is a half-duplex system and both ways on a RS422 network.
4. The converter is de-activated when it receives an OFF command or another converter's ON command, i.e. turning on another converter automatically turns off the currently active one.

NB When using the converter in HeAdEr mode, the end of the data transfer 'into' the addressable converter should be followed by an OFF command if no other commands are sent immediately. This eliminates the possibility of a character (ASCII H) being buffered by the converter as it waits to see if a command follows.

Data Parameters

The converter works with UART data of the following format;

UART Data Parameters	
Data Length	8 bit
Parity	No parity
Stop Bits	1

Setting the converter address

The address that the converter will respond to is set using the Address Switches on the side of the unit.

The valid address range is 1 to 63 (0 is the broadcast address), and is set by moving the switches that add up to the desired address to ON. Figure 1 shows the Address Switches set to address 37 (32+4+1).

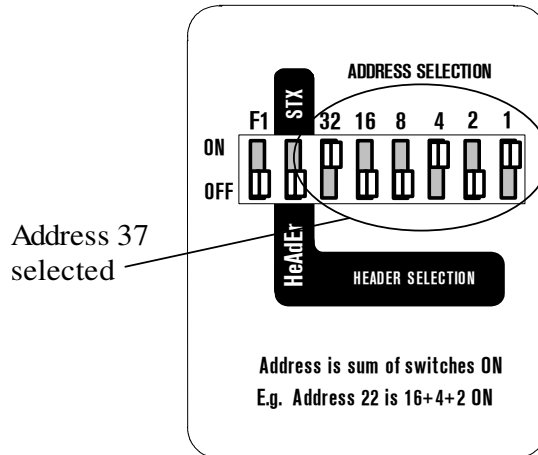

Figure 1 – Address Switches set to address 37



Care must be taken to ensure no address clashes occur since the converter cannot report this.

If the switches are set to 0 (all off), the **ADDRESSED** LED will flash to warn that the broadcast address has been selected. The converter will function as normal but with acknowledgment disabled.

Setting the command header

The header is the first part of a command that tells all converters on a network that the following characters are an instruction.

The Command Header Switch, located in the same bank as the address switches (Figure 2), enables the user to choose between 2 options:

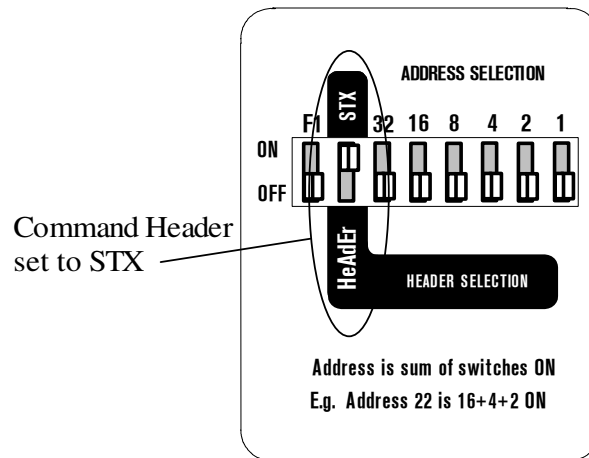

Figure 2 – The Command Header Switch set to STX

STX

The header consists of the single byte STX (ASCII 2), and is for use anywhere that the transmitted data does not include this byte, for example files containing only printable ASCII characters.

HeAdEr

Use this header when transmitting data such as binary files.

The header consists of the 6 byte string; 72(H), 101(e), 65(A), 100(d), 69(E) & 114(r). This is used where all byte values may occur in the transmitted data, in which case a single character header such as STX would be triggered spuriously.

The string HeAdEr, must be sent exactly as shown, with matching case and no other characters between.

F1

The F1 switch, to the left of the Command Header Switch, is reserved for future use and should be left in the OFF position.

Initialising the converter.

When the converter is initially powered on, it requires a number of characters to arrive at the RS485 side in order to detect the baud rate. It cannot respond to any commands, and will remain off, until this has been completed.

Before this auto-bauding is complete, the ADDRESSED LED will glow at half brightness. Once completed, the LED will respond as normal to address commands.

To ensure that the converter initialises correctly, **transmit the acknowledgement string** (page 12) **until the correct response is received**. This should take no more than 3 iterations.

Alternatively, sending 6 dummy characters, such as upper case U's, should be enough to complete auto-bauding.

The Command Set

The General Command

All commands take the following form:

[header][addr 10s][addr 1s][cmd]

where;

- [header] is as selected by the Command Header Switch i.e. STX or HeAdEr.
- [addr 10s] & [addr 1s] is the target converter address from 00 to 63. Both characters must be transmitted (e.g. 6 is 06)
 - 00 is the broadcast address,
 - 01 – 63 are the specific addresses.
- [cmd] is the command to be carried out as detailed below.

Turn On

Command Character: T chr(84)

Description: (T) activates the converter at the specific address and de-activates all others. When used with broadcast address 00, T turns on all converters.

Example: To activate the converter with address 03 and single character header selected, send the four characters:

[STX]03T

Turn Off

Command Character: F chr(70)

Description: (F)also de-activates the converter.

Example: To de-activate all converters set to the HeAdEr command send the nine characters:

HeAdEr00F

Acknowledge

(5258 only)

Command Character: A chr(65)

Description: (A)cknowledge, not available with the broadcast address, is the same as Activate (T), but also returns an acknowledgement string immediately following receipt of the command.

Return: A[addr 10s][addr 1s]

Example: To get an acknowledgement from a converter with address 63 and single character header selected, send:

[STX]63A

The converter will respond with:

A63

Installation

When installing cables and converters to create a network, the environment in which it is to operate alters some installation aspects.

Common to all Set Ups

1. Use a DB9 serial cable to connect the converter to your device.
2. Always connect devices to the RS485 or RS422 network in 'daisy-chain', as shown in figure 3 page15, with each device connected in a row. Never connect devices in a 'star', as each branch will create unwanted reflections, leading to data errors.
 - An exception to this is a cable branch that is less than 5 meters long.

Minimum System

Low electrical noise environments, such as offices, short runs & test benches etc. may permit a system with minimal noise-protection to be installed. This system **should not be used** if power supply ground loops, electrical noise or outdoor use are present.

1. Connect the RS-485 data lines using a single twisted pair.

Master (5001 or 5251)	Slave 1 (5258)	Slave 2 (5258)	Slave 3 (5258)
B(-)	B(-)	B(-)	B(-)
A(+)	A(+)	A(+)	A(+)

2. Connect the RS-422 data lines using two twisted pair.

Master (5005 or 5255)	Slave 1 (5259)	Slave 2 (5259)	Slave 3 (5259)
(-) TXD	(-) RXD	(-) RXD	(-) RXD
(+) TXD	(+) RXD	(+) RXD	(+) RXD
(-) RXD	(-) TXD	(-) TXD	(-) TXD
(+) RXD	(+) TXD	(+) TXD	(+) TXD

3. Connect 9-24Vdc power supplies to each converter. The POWER LED will light up.

Best Practices

This system is the manufacturer's recommended technique and should be used if power supply ground loops, electrical noise or outdoor use are present.

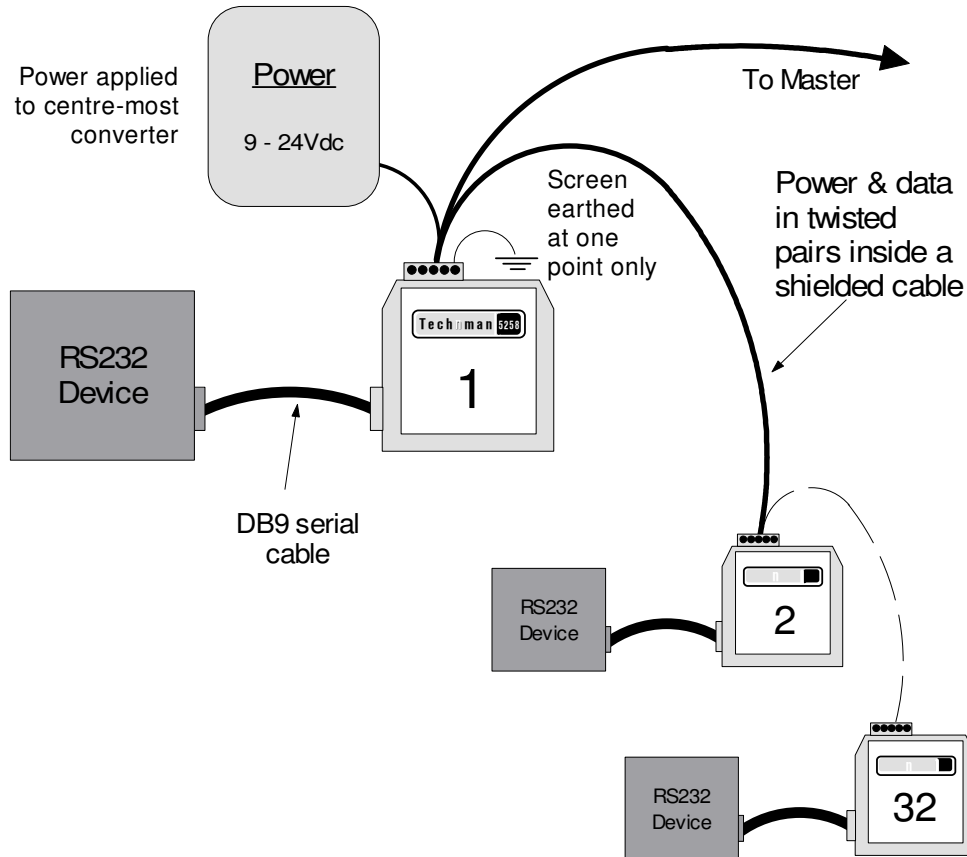

Figure 3 – Multiple converters connected in 'Daisy-chain'.

1. Install the RS-485 network using a **shielded, twin twisted pair** data cable.
2. Connect the RS-485 data lines using one twisted pair as shown on tables above.
3. Connect the power supply to 9 - 24Vdc & GND of the converter closest to the middle of the cable, and feed to all other converters using the other twisted pair. The STATUS LED will light.

-
- An alternative method is to use ground isolated power supplies for each converter
 - Either of these will prevent ground potential differences between distant supplies corrupting data or damaging the converters.



Make sure 24V does not get connected to the RS485 or RS422 terminals.

4. **Do not** remove more than 100mm of shield from each end of the cable when connecting to devices.
5. Connect the cable shield to the SCREEN terminal of each converter, and to ground at **one point only**. This will prevent ground loop currents in the shield corrupting data.

Termination Switches

For best performance of your system, the RS485 cable must be correctly terminated at the ends. Also, the data lines must be biased high & low to ensure a steady state when inactive.

To achieve this:

- Move both termination switches on **the most distant converter** to **ON**.
- Move both termination switches on **all other converters** to **OFF**.

Troubleshooting

The converter cannot be addressed.

No lights are glowing.

- Check the power connections for:
 1. Correct polarity
 2. Supply voltage between 9 and 24Vdc.



The POWER and RXD lights are working correctly.

- Check the data connections for polarity.

The ADDRESS light is blinking.

- The address switches are set to 00, the broadcast address. Move the switches to another address if required.

Specifications

Case Dimensions	80 x 25 x 75 mm (3¼ x 1 x 3")	
Weight	85g (3ozs)	
DIN mount	32 x 15mm, EN50035	
	35 x 7.5mm, EN50022	
	15 x 5mm, EN50045	
Storage temperature	-20° to 70° C (-4° to 158° F)	
Operating temperature	0° to 50°C (32° to 122° F)	
Humidity	15 to 90% relative non condensing	
Transmission Distance	1.8km (6000 feet) at 115.2k baud	
	3.6km (12000 feet) at 56k baud	
Isolation Voltage	1500V max transient ¹	
Power	9-24Vdc regulated or unregulated. NB: Supply voltage must not be allowed to drop below 9Vdc 50mA at 12Vdc on RS485 or RS422 side	
Connectors	RS232	DB9 female
	RS485 or RS422	Plug-able screw terminal connector. 0.2 - 2.5mm ² (AWG 24 -12)
Operating mode	2 wire half-duplex point-to-point or multi-drop	
Data type	8 bit, no parity, 1 stop bit	
Data rates	300 to 115200 bps	
Indicator lights	ADDRESSED, POWER, TXD, RXD,	

¹ Designed to EN 60950 : 1992

Declaration of Conformity 2001

Manufacturer's Name: Technman Electronics Ltd
Manufacturer's Address: PO Box 302 107, Auckland 1330, New Zealand

declares that the product

Product name: Control-it 5000 Series Distributed Input/ Output System
Model numbers: 5001, 5005, 5006, 5007, 5020, 5030, 5040, 5050, 5100, 5101, 5251, 5258
Product options: All

conforms to the following product specifications:

Safety Regulations: Low Voltage Directive 73/23/EEC 22 July 1993 and the UK Electrical Equipment Safety Regulations 1994.
EN 60950:1992+A1+A2+A3- Primary Circuit/ Double insulation
Model 5020- Primary circuit/ Reinforced insulation
Except when these modules are incorporated into a larger mechanical device, in which case a responsible person must ensure that all appropriate safety regulations are met.

EMC Regulations: EMC Directive 89/336/EEC 3 May 1989 and 92/31/EEC 28 April 1992, article 10.1.
EN 55022:1998 Class A Device
EN 55024:1998 I.T. Equipment
EN 50082-2:1995 Generic Industrial Device

The product herewith complies with the requirements of the following Directives and carries the CE marking accordingly:

Low Voltage Directive 73/23/EEC
EMC Directive 89/336/EEC

The product was tested in a typical configuration with a personal computer system.

For compliance information contact:

Director
Technman Electronics Ltd.
PO Box 302 107
Auckland 1330
New Zealand.

or

Quality Assurance Director
Amplicon Liveline Ltd
Centery Industrial Estate
Hollingdean Road
Brighton
UK BN2 4AW

WARNING

This is a class A product. In a domestic environment this product may cause radio interference in which case the user may be required to take adequate measures.

Rev G

Notes